

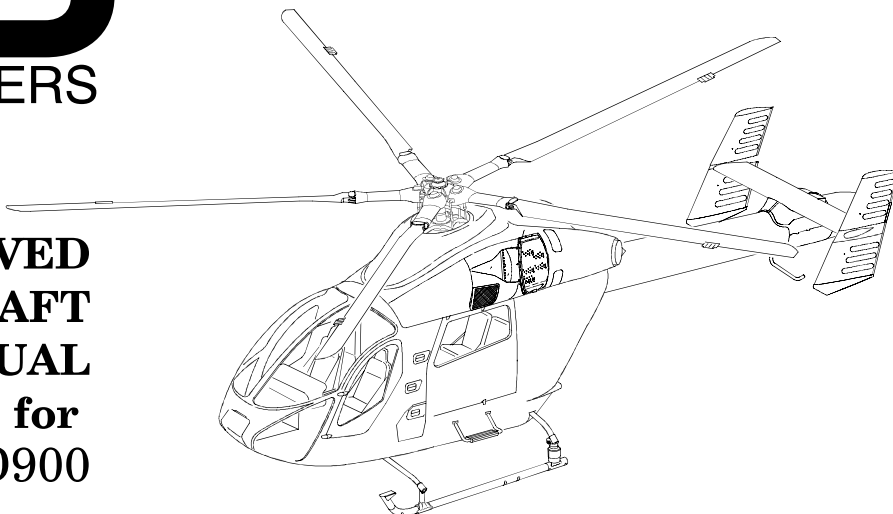

**FAA APPROVED  
ROTORCRAFT  
FLIGHT MANUAL  
for  
Model MD900**



**(902 Configuration with PW 207E)**

Type Certificate No. H19NM

Approved By: \_\_\_\_\_

*S. J. Johnson*  
Manager, Flight Test Branch, ANM-160L  
Federal Aviation Administration  
Los Angeles Aircraft Certification Office  
Transport Airplane Directorate

Original Approval Date: July 28, 2000

Reissue #1: December 2, 2008

Reissue #2: *NOVEMBER 6, 2009*

**THE FAA APPROVED ROTORCRAFT FLIGHT MANUAL CONSISTS OF THE FOLLOWING SECTIONS.**

**SECTION II - LIMITATIONS  
SECTION III - EMERGENCY PROCEDURES  
SECTION IV - NORMAL PROCEDURES  
SECTION V - PERFORMANCE DATA  
SECTION X - OPTIONAL EQUIPMENT  
SECTION XI - CATEGORY-A OPERATIONS**

The helicopter must be operated in compliance with the operating limitations as set forth in section II of this manual and any additional limitations from Section X as a result of an installed optional equipment item.

Sections III, IV, V, X and XI contain recommended procedures and data and are FAA approved.

**THIS MANUAL MUST BE KEPT IN THE HELICOPTER AT ALL TIMES.**

*Copyright © 1999-2009 by MD Helicopters, Inc.  
All rights reserved under the copyright laws.*